

## WALL FIXING KIT INSTALLATION INSTRUCTIONS

IMPORTANT NOTE:- ENSURE ALL RELEVANT PERSONNEL READ THESE INSTRUCTIONS PRIOR TO OPERATION

### Fixings Included

**A**



4 off

**B**



4 off

**C**

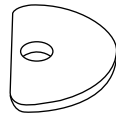

4 off

**D**



4 off

**E**



2 off

**F**



16 off

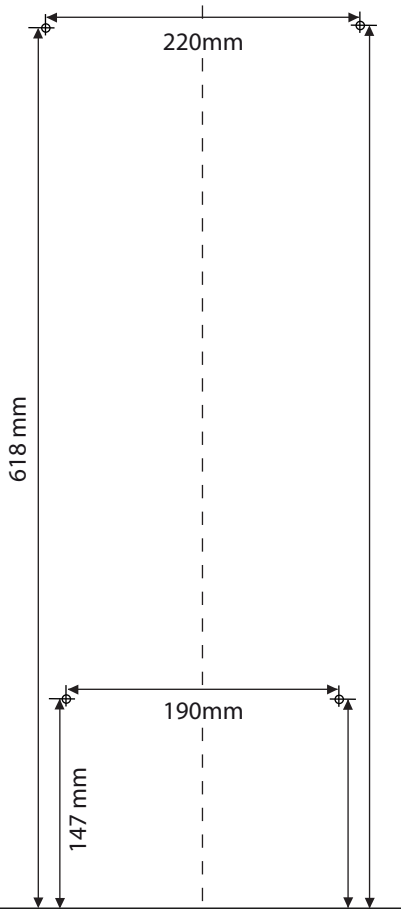

**1**

Select a suitable wall on which to mount the unit. Using the unit as a template, mark the position of the 4 holes checking the dimensions (as seen above) afterwards with a tape measure. Drill the wall using an 8mm masonry bit and plug with the wall plugs provided.

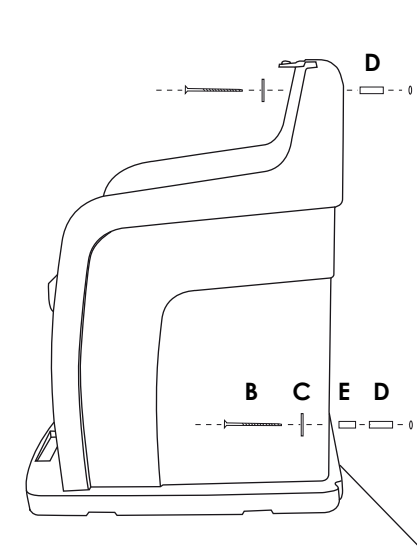

**2**

Open the lid of the unit to expose the fixing holes.

Starting with the top fixings, place the screw through the washer then through the hole in the unit. Thread the 35mm long spacer (**D**) onto the screw then using a screw driver tighten the screw until securely fixed into the wall.

With the bottom fixings repeat the above steps only adding an extra 15mm long spacer (**E**) before screwing into the wall.

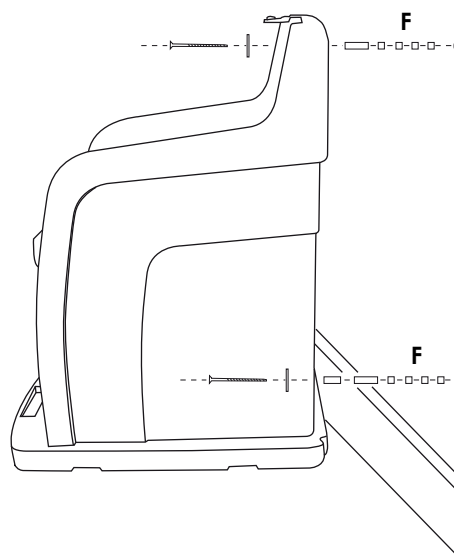

**NOTE:** If the unit is being fixed to a wall which is not flat e.g. has a skirting board, more spacers must be added.

4 off 3mm spacers (**F**) are provided for each fixing point (16 in total) to fill the gap between the unit and the wall.